

QC Inclinometer Casing Installation Guide

51150099

Copyright ©1997 Slope Indicator Company. All Rights Reserved.

Inclinometer casing should be installed by technically-qualified personnel. This publication is provided as a guide only and is not intended to substitute for the expertise of a qualified engineer or to supersede project specifications or instruction manuals.

Slope Indicator Company
A Boart Longyear Group Company
3450 Monte Villa Parkway
Bothell, WA 98021-8906 USA
Tel: 425-806-2200 Fax: 425-806-2250



SINCO 70001920 0697

Contents

Introduction.	1
Assembling QC Casing	6
Installing QC Casing	13
Terminating the Installation .	26

Introduction

The Advantages of QC Inclinometer Casing

QC inclinometer casing combines the quality and precision of Slope Indicator's traditional inclinometer casing with a patented* coupling system that saves time and virtually eliminates assembly mistakes.

The patented QC coupling system provides snap-together convenience and creates strong, flush joints without glue, rivets, or tape. The QC joint won't pull part. It won't twist out of alignment. It won't break if you bend it. And it won't leak or collapse under the pressure of grout.

Quality and precision are easily seen in the spiral-free, machine-broached guide grooves. The shape of the grooves promotes repeatable positioning of the inclinometer probe. The uniform depth of the grooves prevents weak spots along the casing wall that could fail under the pressure of grout.

If you're an engineer who requires accurate inclinometer data, or if you are installer who needs reliable casing that installs quickly, you'll like the way QC inclinometer casing performs.

*US Patent #5,015,014

QC Casing Part Numbers

85 mm (3.34 inch) Casing Part No.

10-Foot Section	51150310
5-Foot Section	51150311
Telescoping Section.	51150320
Bottom Cap	51150330
Top Cap	51100500
Locking Cap with Padlock	51100550
Splice Kit, Male.	51150350
Splice Kit, Female.	51150351
85 mm Grout Valve, Gasket-Type.	51150335
85 mm Grout Valve, Quick-Connect.	51150340
Pipe Clamp	50100200

70 mm (2.75inch) Casing. Part No.

10-Foot Section	51150210
5-Foot Section	51150211
Telescoping Section.	51150220
Bottom Cap	51150230
Top Cap	51101500
Locking Cap with Padlock	51101550
Splice Kit, Male.	51150250
Splice Kit, Female.	51150251
70 mm Grout Valve, Gasket-Type.	51150235
70 mm Grout Valve, Quick-Connect.	51150240
Pipe Clamp	50100200

QC Casing Performance Tests

During the development of QC casing, Slope Indicator established a series of tests to quantify and improve the strength of QC coupling system. The final testing of QC casing was observed by Pacific Testing Laboratories and the results of the testing were certified in a report entitled “Engineering Review of Inclinator Casing Strength Tests.” Please contact Slope Indicator if you are interested in obtaining a copy of the PTL report.

Pull Test

Purpose: To test the performance of QC casing joints under tensile loads.

Materials: QC casing section samples, loading frame, and NIST-traceable equipment including a calibrated hydraulic ram and pressure gauge.

Procedure: The casing section samples were assembled and mounted in the loading frame. The samples were loaded until the casing joints failed.

Results: Both 85 mm (3.34 inch) and 70 mm (2.75 inch) casing sample joints withstood 635 kg (1400 lb) of tension.

Torque Test

Purpose: To test the performance of QC casing joints under twisting forces that could cause misalignment of casing grooves.

Materials: QC casing section samples, torque test frame with lever arm, NIST Class F traceable weights.

Procedure: The casing section samples were assembled and mounted in the torque test frame. The weight suspended from the lever arm was increased until the casing joints failed.

Results: Both 85 mm (3.34 inch) and 70 mm (2.75 inch) casing sample joints withstood 33 N.m (25 ft.lb) of torque.

Bending Test

Purpose: To test the performance of QC casing joints under bending moments.

Materials: QC casing sections, a test frame, and NIST Class F traceable weights.

Procedure: Casing sections were assembled and then supported at opposite ends, with the unsupported joint in the middle. Weights were suspended from the casing sections on both sides of the joint to create a bending moment across the joint. Weight was then increased until the joint failed.

Results: Both 85 mm (3.34 inch) and 70 mm (2.75 inch) casing joints withstood a bending moment of 186 N.m (140 ft.lb).

Pressure Test

Purpose: To test the O-ring seals and the collapse strength of the QC joint by subjecting them to compressive forces.

Materials: QC casing sections, a water-filled pressure vessel, and an NIST-traceable pressure gauge.

Procedure: Casing sections were assembled and placed in the pressure vessel, which was designed to apply pressure to the casing wall and joint, but not to casing ends, which were left open to atmosphere. Water pressure was increased until the casing failed.

Results: The 85 mm (3.34 inch) casing joints withstood a minimum of 12.4 bar (180 psi). The 70 mm (2.75 inch) casing joints withstood 16.5 bar (240 psi).

Assembling QC Casing

Assembling QC Casing

QC Casing Sections

Each section of casing has a male end with an alignment key, an O-ring, and a lock ring, and a female end with a keyway. It takes about 30 pounds to snap two sections of casing together.

The O-ring and lock-ring are greased at the factory and protected by a cap. At assembly time, remove the cap and check that the O-ring and lock ring are still greased. Be sure to keep casing ends clean.

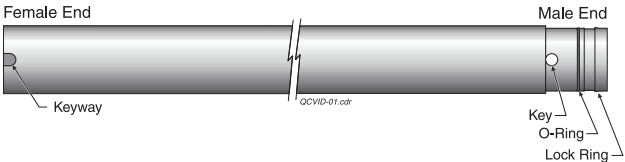

Installing a Bottom Cap or Grout Valve

1. Remove protective cap.
2. Place bottom cap or grout valve on ground with male end up.
3. Push female end of casing section onto bottom cap or grout valve. You will hear a "snap" as the lock ring is seated.

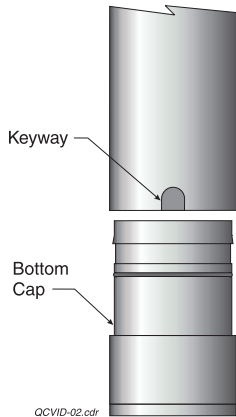

Assembling Casing Sections

1. Remove protective caps and check that O-ring and lock ring are greased.
2. Align the key and keyway of the two sections.
3. Push the sections together until the joint snaps closed. If the O-ring is caught in the keyway, pull the sections apart and start again.

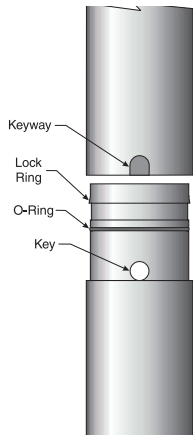

Speed Hint

You may find this alternative assembly procedure easier:

1. Push the sections together until the end of the casing touches the alignment key.
2. Turn the casing into alignment.
3. Snap the joint closed.

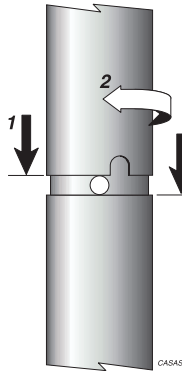

Assembling Telescoping Sections

Each QC telescoping section allows six inches of compression or extension. The sliding sleeves of the section are equipped with QC ends, allowing the telescoping section to be inserted between two QC casing sections.

To accommodate settlement, the telescoping sections should be installed with sleeves extended. Use one rivet to hold each sleeve. Place the rivet about 1/2 inch from the edge of the section body and aligned with the key and keyway (see drawing on the next page). To counter buoyancy, be sure to apply a down force to the bottom of the casing. The single rivets may not hold if you apply a down force from the top.

Assembling QC Casing

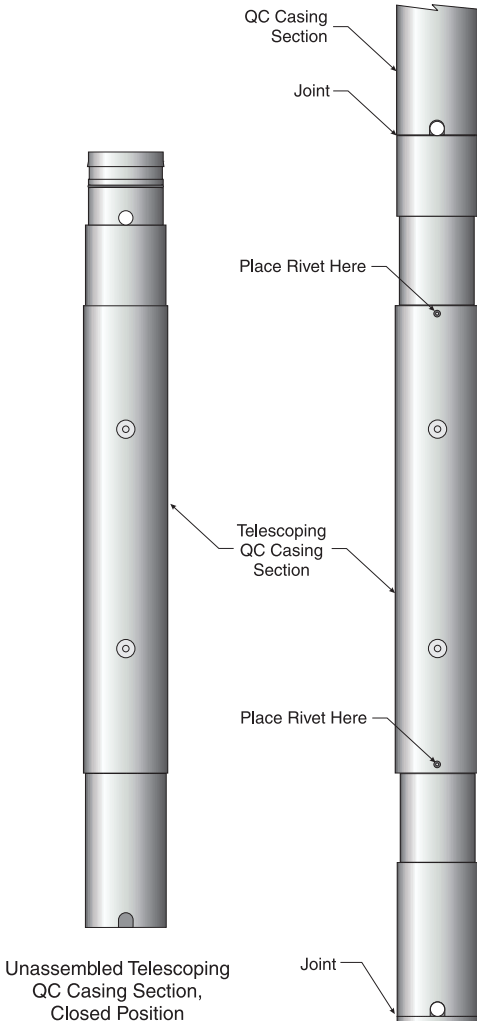

Taking Apart QC Casing

1. Use a hacksaw to cut the casing. Start cutting just below the alignment key. End the cut about 3½ to 4 inches above the joint as shown in the drawing. Cut through the first layer of casing only. Do not allow cuts to intersect.
2. Pry the casing loose, starting at the key. Then bend the casing until you can remove it.

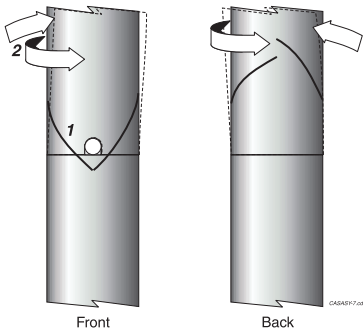

Reassembling QC Casing

1. Remove burrs and rough edges.
2. Glue and rivet the reassembled joint. Place rivets at 90 degree intervals around the joint, starting the first rivet just above the keyway.
3. Seal the entire joint with tape.

Splicing QC Casing

Damaged QC casing can be repaired using a QC casing splice kit. Splice kits include a male or female coupling, self-tapping screws, and vinyl tape. You will need a hack-saw, drill, and screwdriver.

1. Cut off damaged casing. Remove burrs.
2. Slide the splice coupling onto the end of the casing and align it with the grooves in the casing.
3. Drill holes in the casing using the pre-drilled holes on the splice coupling as a guide.
4. Insert the self-tapping screws into the pre-drilled holes and screw them into the casing.
5. Seal the joint with vinyl tape.
6. The casing section now has a good QC end and can be used normally.

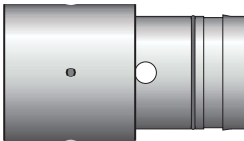

Male Splice Coupling

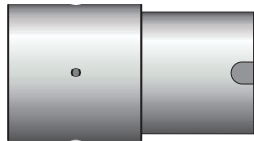

Female Splice Coupling



Self-Tapping Screws

Vinyl Tape

QCVID-05.cdr



Self-Tapping Screws

Vinyl Tape

QCVID-06.cdr

Installing QC Casing

Installation Concerns

How to Store Casing

Casing should be supported evenly so that it does not warp or bend during storage. In the field, keep casing in the shade, if possible, since prolonged exposure to the heat of direct sunlight can cause deformation.

Check Borehole Depth

Check the depth of the borehole before you begin installing the casing. Also consider that grout valves or external weights may require a deeper borehole.

Align Grooves with Direction of Movement

It is important to align one set of casing grooves with the expected direction of movement (see drawing below). A guide line is printed on the casing to help you maintain this orientation.

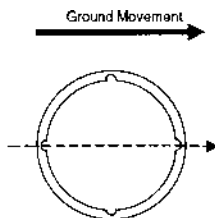

Using Pipe Clamps

Use pipe clamps to hold the casing at the borehole collar while you add the next section of casing. In dry boreholes or in situations where down hole problems seem likely, rig a safety line to provide extra security and a way to retrieve the casing, if necessary.

- 1.** Attach Clamp A to the top of the first section of casing. Lower the casing into the borehole until the clamp rests on the borehole collar.
- 2.** Attach Clamp B to the top of the next section. After you snap the new section onto the casing, remove Clamp A and lower the new section into the borehole until Clamp B rests on the borehole collar.
- 3.** Now attach Clamp A to the next section of casing, make the joint and lower it into the borehole. Continue alternating Clamp A and clamp B on successive sections of casing.

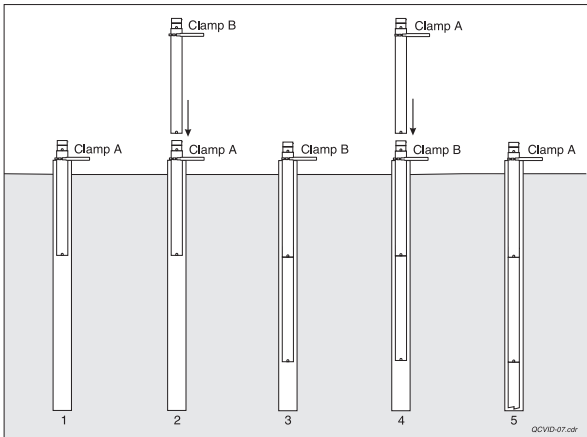

Casing Buoyancy

Casing will float in water-filled boreholes, so you must fill it with water to install it down hole. However, when you pump grout into the borehole, the water-filled casing becomes buoyant again, because the grout is denser than water.

To counter this buoyancy, you should apply a down force at the bottom of the casing. You can lower a steel pipe to the bottom of the casing or you can suspend a non-retrievable weight from the bottom of the casing when you install it. A suspended weight requires a deeper borehole and may require use of a safety line.

Note that a down force applied at the top of the casing is likely to distort the casing profile. For this reason, we recommend that you do not park a drill rig over the casing or apply any other top-down method of counteracting buoyancy.

Grouting

You will need a mixer, a grout pump, a pipe or hose for delivering the grout, and optionally, a grout valve installed in the bottom section of the casing. We recommend that you do not mix the grout by hand. We also recommend that you do not use a water pump to place the grout, since pumping grout would damage it.

Properly mixed grout should be free of lumps. It has to be thin enough to pump but thick enough to set in a reasonable length of time. If the mixture is too watery, it will shrink excessively, leaving the upper portion of the borehole ungrouted. Also, avoid the use of admixtures and grouts that cure at high temperature since these may damage the casing.

Grouting continued**Grout Mixes for Inclinometers**

Mix cement with water first. Then mix in the bentonite. Adjust the amount of bentonite to produce a grout within the consistency of heavy cream. If the grout is too thin, the solids and the water will separate. If the grout is too thick, it will be difficult to pump.

The mix for hard and medium soils has a 28 day compressive strength of about 100 psi, similar to hard clay. The modulus is about 10,000 psi.

The mix for soft soils has a 28 day compressive strength of about 4 psi, similar to very soft clay.

Bentonite-Cement Grout for Hard and Medium Soils		
Materials	Weight	Ratio by Weight
Portland Cement	94 lb (1 bag)	1
Bentonite	25 lb (as required)	0.3
Water	30 gallons	2.5

Bentonite-Cement Grout for Soft Soils		
Materials	Weight	Ratio by Weight
Portland Cement	94 lb (1 bag)	1
Bentonite	39 lb (as required)	0.4
Water	75 gallons	6.6

Installation Methods

Pre-Grouting the Borehole

1. Clear the borehole of debris. Check the borehole depth. Lower the grout pipe to the bottom of the borehole. Pump in the grout and then retrieve the grout pipe.
2. Attach the bottom cap to the bottom section of casing.
3. Install casing to the specified depth. Keep casing filled with water to counteract buoyancy.
4. Lower a steel bar or drill pipe to the bottom of the casing to counteract buoyancy. Allow the grout to set. Later, top off the borehole with grout and install a protective cover.

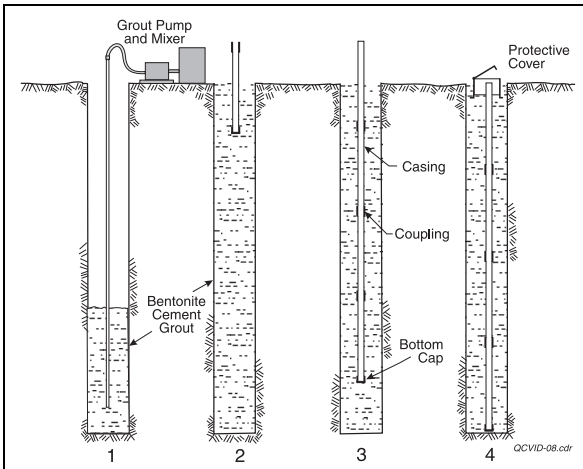

Using an External Grout Pipe

This method is used in boreholes that have room for a grout pipe (or hose) in the annulus between the casing and the borehole wall.

1. Clear the borehole of debris. Check the borehole depth. Attach bottom cap. Attach grout hose, if used.
2. Install casing to the specified depth. Lower pipe to the bottom of the casing to counteract buoyancy. Cap the casing to prevent entry of grout.
3. Lower the grout pipe to the bottom of the borehole and pump in grout. You may have to “jet” the pipe into place by pumping a mixture of grout and water. Then pump in grout and retrieve the grout pipe.
4. Allow the grout to set. Later, top off the borehole with grout and install a protective cover.

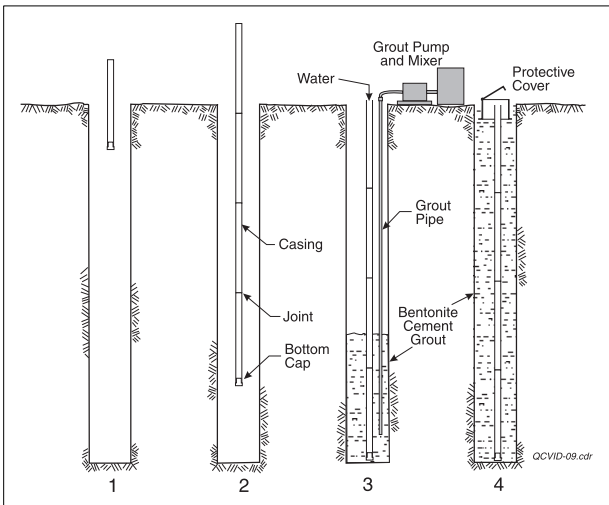

Using a Grout Valve

Grout valves are used when casing is installed in small diameter boreholes that do not allow use of an external grout pipe. The grout valve is a one-way valve installed in the bottom cap of the casing. A grout pipe is lowered through the casing to mate with the grout valve and deliver grout.

Grout valves add about two feet to the effective length of the casing, so the borehole should be about two feet deeper to compensate.

Types of Grout Valves

Grout valves are illustrated on the next page.

The gasket-type grout valve couples with the grout pipe via a straight pipe with a rubber gasket at its base. The grout pipe is lowered onto the grout valve rest on the gasket. This prevents grout from entering the casing. However, when the grout pipe is withdrawn, grout spills out of the pipe into the casing and must be flushed out with water.

The quick-connect grout valve has a quick connect fitting that mates with another quick-connect fitting that is attached to the grout pipe. When the grout pipe is withdrawn, very little grout leaks into the casing. However, as you are retrieving the pipe, you must be careful not to spill grout into the casing, since you will have to flush it out.

Installing QC Casing

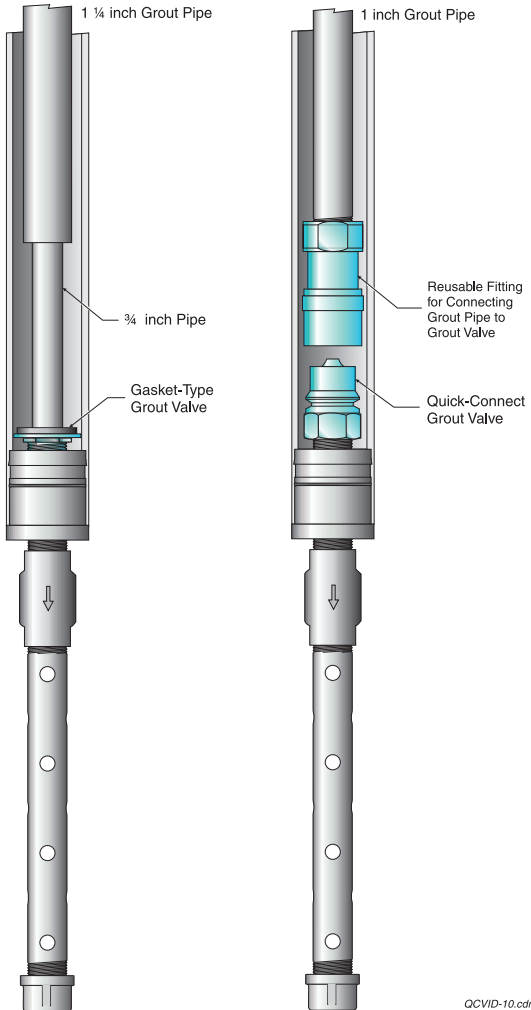

Using a Grout Valve

1. Install grout valve on bottom section of casing. Install casing to the required depth.
2. Lower the grout pipe into the casing until it contacts the grout valve. Rotate the pipe until it slips onto the grout valve connector. Successful coupling can be tested by pumping water through the grout pipe. If the water level inside the casing rises, reposition the pipe and test again.
3. Pump in grout until it spills out at the surface. The weight of the grout pipe will keep the casing from floating. Note: If you installed dry casing, pump water into the casing as the grout level rises.
4. When you retrieve the grout pipe, the casing will float upwards, so you must be prepared to hold the casing down as you retrieve the pipe. Follow either of the two procedures below:
 - **Gasket-type valve:** If you are using the gasket-type grout valve, raise the grout pipe well above the grout valve and pump water into the casing to flush out the grout. When clean water spills out at the surface, gradually lower the pipe and continue to flush until you have flushed grout from the bottom of the casing. Then disconnect the pipe at the surface and leave it in the casing to counteract buoyancy. When the grout sets, withdraw the pipe.

Using a Grout Valve continued

- **Quick-connect valve:** If you are using a quick-connect grout valve, retrieve the grout pipe and flush it with water. Then lower pipe into the casing to counteract buoyancy. You must avoid contact with the quick-connect valve, since it can be opened easily. You can fabricate a bracket that fits over the quick-connect valve (the quick connect fitting stands about 3 inches off the bottom of the casing) or you can use a 1.5-inch schedule 40 water pipe (which has ID of about 1.6 inches), which will slip over the quick-connect valve. After the grout sets, withdraw the pipe.
5. Finally, top off the borehole with grout and install a protective cover.

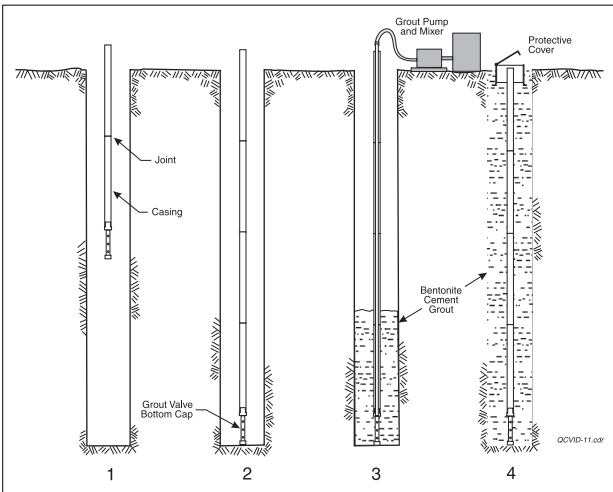

Stage Grouting

In stage grouting, grout backfill is placed in stages, so that the pressure of grout never exceeds the collapse strength of the casing. In general, you should consider stage grouting when the depth of the borehole exceeds 200 feet.

- Grout can be delivered by hose or pipe. Hose must be installed with the casing, but it is disposable and can be left in place after grouting.
- Stage grouting with hoses requires at least two hoses. The first pipe should extend to the bottom of the borehole. The next pipe should extend to bottom of the the next stage, and so on.
- Be sure to label or color-code each grout pipe to avoid accidentally pumping grout or water down the wrong pipe.
- Make some provision to counter buoyancy of the casing. This is best done by applying a down force at the bottom of the casing.

Overview of Stage Grouting with Hoses

- 1.** Hoses are fixed to the casing as shown in the drawing below. In Stage 1, calculate the volume of grout needed to backfill the borehole above the end of the Stage 2 grout hose. Pump in that volume of grout plus about 30%. Leave the Stage 1 grout hose in place.
- 2.** Pump water through the Stage 2 grout hose. The bottom of the Stage 2 hose should be below the surface of the grout, and pumping in water should flush grout from the borehole. If no grout appears, pump more grout through the Stage 1 hose and then test again. Using this method, you can be relatively certain that Stage 1 is grouted satisfactorily. Continue pumping water through the Stage 2 hose until “clear” water flushes from the borehole. This ensures that the Stage 2 hose will be clear for use later.
- 3.** When the Stage 1 grout has set, grout Stage 2. Since the bottom of the casing is now grouted in place, buoyancy will no longer be a problem.

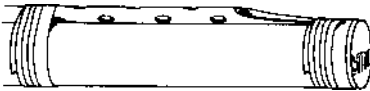

To prepare a polyethylene hose for grouting, cut a wedge-shaped end and several additional holes. Then tape the hose to the casing.

Termination

Protective Caps and Enclosures

Project specifications usually require that the installation be protected from traffic, vandalism, and debris. In some locations, a locked cap may provide sufficient protection. In other locations, a locking steel enclosure or a monument case may be required.

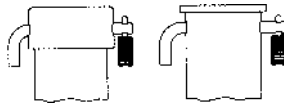
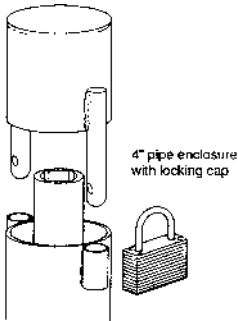

Locking Caps

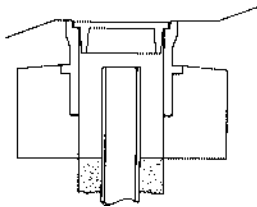

Monument Case

Accommodating a Pulley Assembly

Keep in mind that the inclinometer user will want to attach a pulley assembly to the top of the casing. If the top of the casing is deep inside a protective pipe, the user will not be able to attach the pulley. Ideally, the enclosure should be installed so that the top of the enclosure is only an inch or two above the top of the casing. When the top of the casing is deeper, the enclosure must provide a 10 inch clearance around the casing if the pulley is to be attached directly to the casing.