

# Portable Digitilt Tiltmeter

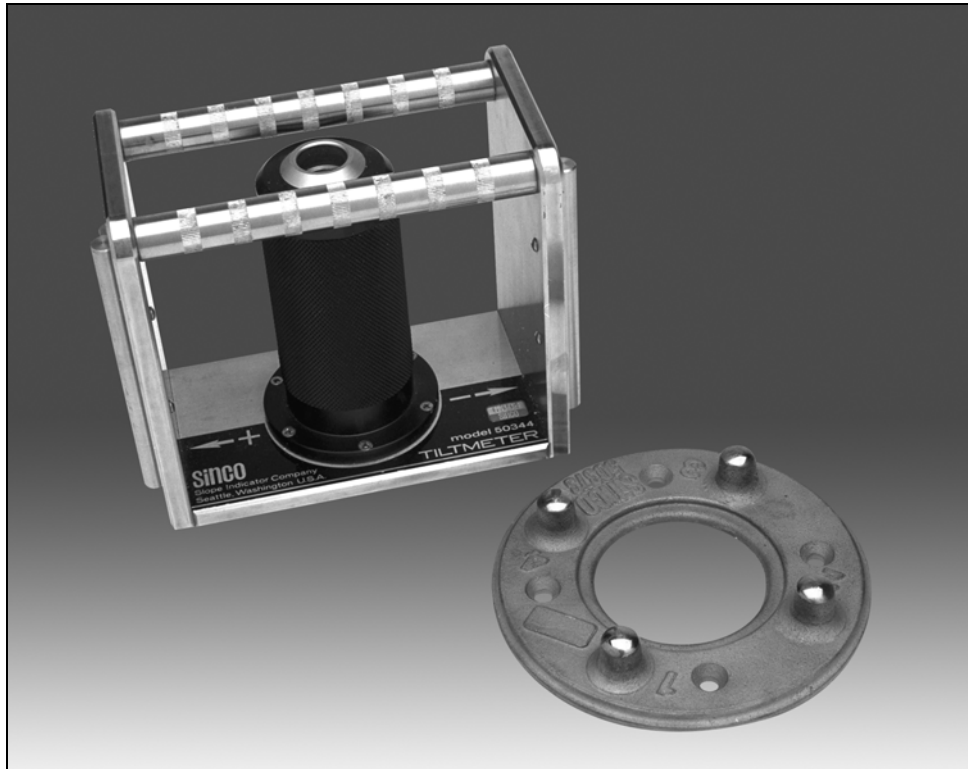

## Applications

The portable tiltmeter is used to monitor changes in the inclination of a structure. Typical applications are:

- Monitoring rotation caused by mining, tunneling, soil compaction, or excavation.
- Monitoring rotation of retaining walls, piers, and piles.

## Operation

A tiltmeter system includes tilt plates, the portable tiltmeter, and a readout unit.

The tilt plates are mounted on the structure in specified locations. They are typically bonded to the structure, but may also be screwed to the surface.

To obtain readings, the operator connects the tiltmeter to the readout unit and positions the tiltmeter on the tilt plate. The bottom surface of the tiltmeter is used with horizontal tilt plates, and the side surfaces of the tiltmeter are used with vertical tilt plates.

After noting the displayed reading, the operator rotates the tiltmeter 180° and obtains a second reading. The two readings are later combined.

Changes in tilt are found by comparing the current reading to the initial reading and converting the results to angles or displacements.

## Advantages

**Economical:** One tiltmeter can be used to monitor any number of inexpensive tilt plates.

**Easy to Install:** Bronze tilt plates can be bonded or screwed to the structure.

**Easy to Use:** Tilt readings are obtained quickly and easily by a single operator.

**Rugged, Reliable, and Accurate:** The tiltmeter uses the same proven force-balanced, servo-accelerometer technology used in the Digitilt inclinometer probe.

**PORTABLE TILTMETERS****Metric Tiltmeter . . . . .50304410**

Includes case and jumper cable (3 m) for connecting to readout.

**Sensor:** Digitilt uniaxial force-balanced servo-accelerometer.

**Range:**  $\pm 53^\circ$  from vertical.

**Resolution:** 8 arc seconds.

**System Repeatability:**  $\pm 40$  arc seconds.

**Materials:** Stainless steel frame, anodized aluminum housing.

**Dimensions:** 152 x 89 x 178 mm.

**Weight:** 4.5 kg.

**English Tiltmeter . . . . .50304400**

Includes case and jumper cable (10') for connecting to readout.

**Sensor:** Digitilt uniaxial force-balanced servo-accelerometer.

**Range:**  $\pm 35^\circ$  from vertical.

**Resolution:** 10 arc seconds.

**System Repeatability:**  $\pm 40$  arc seconds.

**Materials:** Stainless steel frame, anodized aluminum housing.

**Dimensions:** 7 x 10 x 7 inch.

**Weight:** 10 lb.

**TILT PLATES****Tilt Plate . . . . . 50307300**

**Mounting Method:** Epoxy bonding compound or screws.

**Material:** Bronze.

**Diameter:** 140 mm (5.5").

**Height:** 24 mm (0.95").

**Center Hole:** 63 mm (2.5").

**Weight:** 0.68 kg (1.5 lb).

**Tilt Plate Cover . . . . . 50307350**

Includes anchors.

**Epoxy Bonding Compound . . . . . 50305500**

0.45 kg (1lb). For mounting up to five tilt plates. Requires ambient temperature above 4.5 °C (40 °F) for curing.

**READOUTS**

Compatible readouts include the Digitilt Data-Mate and the Digitilt 09. See separate data sheet for features and specifications.