

# Digital Tape Extensometer

## Applications

The tape extensometer is used to determine changes in the distance between pairs of reference points. Typical applications include:

- Monitoring convergence of tunnel walls.
- Monitoring deformations in underground openings.
- Monitoring displacement of retaining walls, bridge supports, and other concrete structures.

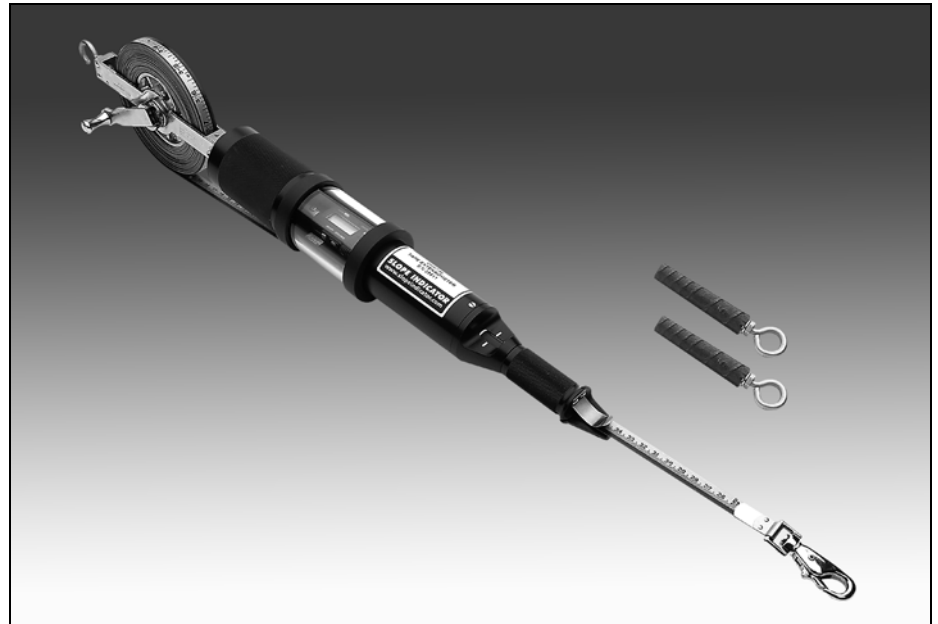
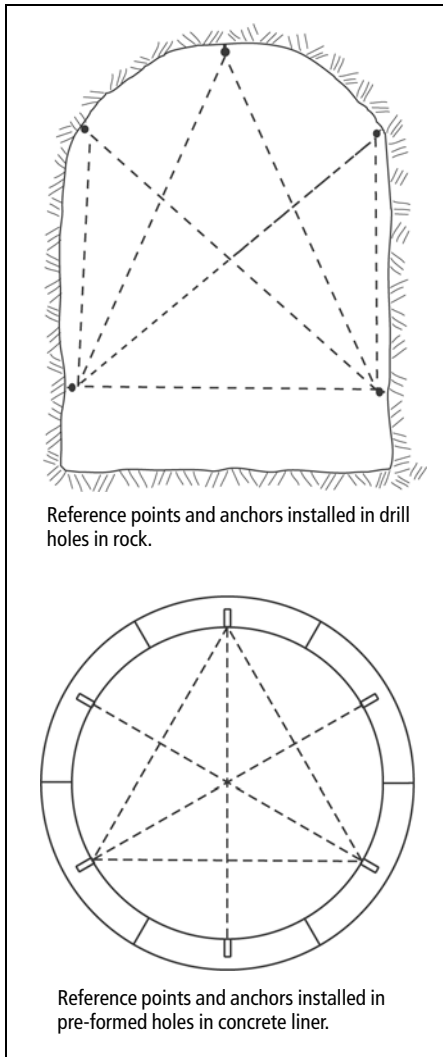

## Operation

Stainless steel reference points are installed at measurement stations along the tunnel or structure. The points may be secured directly to the structure or threaded into groutable anchors or expansion anchors.

To obtain a measurement, the operator stretches the tape between two reference points, hooking the free end of the tape to one point and the instrument body to the other.

The operator tensions the tape by turning a knurled collar until two index marks are aligned, and then notes the reading from the tape and the digital display. The sum of these readings is the distance between the two reference points. (Note that the tape extensometer is intended for relative measurements and cannot be used as a surveyor's chain.)

By comparing current readings to initial readings, the operator can calculate the change in distance between the two points.

## Advantages

**Repeatable Measurements:** The digital tape extensometer provides measurements repeatable to  $\pm 0.13$  mm or  $\pm 0.005$ " over spans up to 30 meters or 100 feet.

**Quick-Connect Reference Points:** The hook and eyebolt system used by the tape extensometer is more economical and faster to use than threaded systems. The system provides unrestricted movement of the tape and is very easy to keep clean.

**Compact, Strong, & Lightweight:** The tape extensometer with tape reel is only 610 mm (24") long and weighs only 2 kg (4.5 lb). Precision parts are protected by a strong aluminum body and a shatterproof plastic lens.

**METRIC TAPE EXTENSOMETER**

Unit with 20 m tape . . . . .51811510

Unit with 30 m tape . . . . .51811530

Display Resolution: 0.01mm.

Measurement Repeatability:  $\pm 0.10$  mm.

**Steel Tape:** 13 mm x 20 m or 13 mm x 30 m, perforated at 50 mm intervals, graduated in mm. Thermal coefficient of expansion is 11.6 ppm per degree.

**Dimensions:** 70 mm OD, 610 mm overall length.

**Weight:** Approximately 2 kg.

**Batteries:** SR44 silver oxide cell. Battery life is approximately 3 years.

**Operation Temperature:** 0 to 40 °C.

**ENGLISH TAPE EXTENSOMETER**

Unit with 66' tape . . . . . 51811500

Unit with 100' tape . . . . . Special Order

Display Resolution: 0.0005 inch.

Measurement Repeatability:  $\pm 0.005$  inch.

**Steel Tape:** 0.5" x 60 or 0.5" x 100', perforated at 2-inch intervals with 1/8" graduations. Thermal coefficient of expansion is 6.45 ppm per degree F.

**Dimensions:** 2.75" OD, 24" overall length.

**Weight:** Approximately 4.5 lb.

**Batteries:** SR44 silver oxide cell. Battery life is approximately 3 years.

**Operation Temperature:** 0 to 40 °C.

**REFERENCE POINTS**

Reference Point. . . . .51812000

Stainless steel eyebolt with lock nut. Threads into groutable or expansion anchor.

Groutable Anchor . . . . .51804304

16 mm O.D. (#5 rebar). Tapped for reference point.

Expansion Anchor . . . . .51812050

Tapped for reference point. Requires 35 mm (1.375") drill hole.

**ACCESSORIES**

Carrying Case . . . . .51812100

Sturdy vacuumed formed ABS plastic carrying case with foam lining for shock protection.

Metric Replacement Tape, 20 m . .11801370

English Replacement Tape, 66' . . .11801380